

CHR

Heat Recovery

Ventilators



confidence
air

Index

01	Our Company.....	03
02	CHR Unit.....	04
03	Unit Specifications.....	05
04	Components.....	06
05	Performance Datas.....	07
06	<u>Accessories</u>	16



About Confidence Air

Confidence Air has been established to produce suitable solutions for all kinds of filtration demands with its young, dynamic staff and customer satisfaction-based service approach.

Our company, which has high-quality product groups and fast service facilities in all areas that need fresh air and equipment to meet the demands, aims to become one of the sector's pioneers in a short time.



CHR Unit

The studies show that people spend most of their lives in indoor conditions in civilised cultures. Because of that, air quality becomes one of the core point for health. On the other hand, increasing demand for energy efficiency and the fact that energy sources are limited, consumption of the energy should be more efficient. Confidence Air heat recovery ventilators are designed for longlife usage to supply both energy efficiency and air quality.

Confidence Air Heat Recovery Ventilator range has 8 models between 800m³/h and 6.000m³/h. The design made for recovering and transferring the thermal load on the exhaust air to fresh air.

Functions

CHR units;

- Supplying fresh air to indoor
- Exhausting
- Filtering of supply air
- Transferring energy of the exhaust air to fresh air

Advantages;

- Double drain pan
- Mounting from both sides thanks to functional design
- Removable plate exchanger
- Electrical heater or water coil application(optional)
- Easy replacing of air inlet-outlet connections
- High efficient Eurovent certified plate heat exchangers
- Low noise level and high efficiency by using back curved plug fans
- Flexible mounting solution with alternative duct connection covers
- Easy maintenance for all components without demounting of unit
- Thermal and sound isolation(Non flammable)
- Functional control panel

Why To Choose Confidence Air Heat Recovery Ventilators

- Low Energy Consumption with high efficiency plug fans
- Eurovent-certified aluminum recuperator of brand for high thermal efficiency
- Low noise levels
- G class filter
- Smart automation solutions(optional)
- Proportional speed control
- 8 different models between 800m³/h and 6.000m³/h
- Easy mounting for electrical heaters
- Water coil (optional)



Unit Specifications

Low noise level and high efficiency by using back curved plug fans

CHR Units use direct driven plug fans with AC motors. Thanks to aerodynamic structure of their wings, they reach high efficiency levels. They can work on high performances with low noise levels.

Easy maintenance for all components without demounting of unit
All the components are detachable in case of maintenance needs without demounting of the unit.

High efficiency with Eurovent certified heat exchangers

The exchangers that are used in CHR units are tested in laboratories and their performance are certified. Exchangers supply low pressure drops thanks to state of art technology wing structure which brings energy efficiency as well as lower capacity needs on heating and cooling.

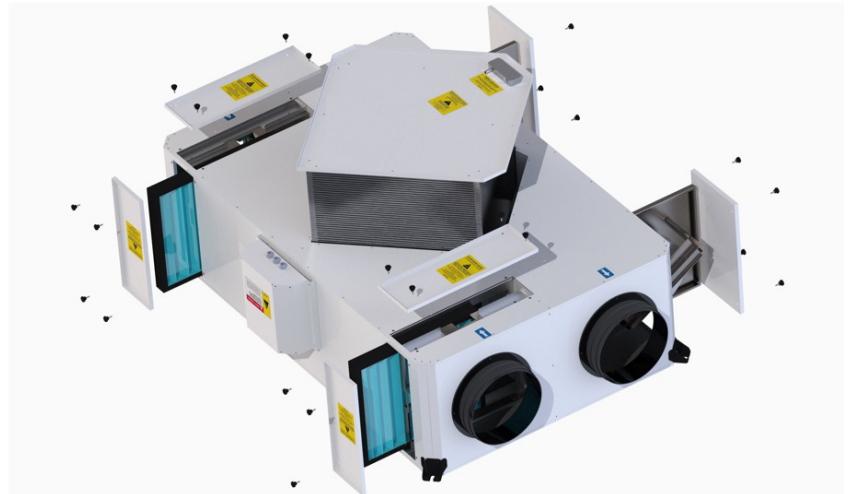

Thermal and sound isolation (Flame retardant)

Flame retardant, polyurethane foams are used in CHR units to assure thermal and sound isolation. The flame retardant feature of isolation prevents thermal transfer. Fans, filters and heat recovery exchangers of the CHR are reachable in false ceiling through service doors.

Components

▶ Heat Recovery Exchanger

- Longlife, plate type heat recovery exchanger
- High thermal efficiency
- Low pressure drop
- Eurovent certified
- Detachable, easy maintenance
- Washable

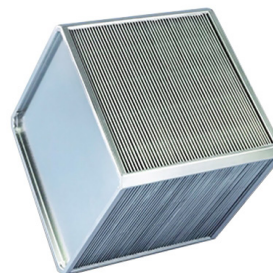

▶ Plug Fan

- Direct driven Plug fans with, AC motor
- Mono-phase connection
- Low electrical consumption
- Low noise level
- Protection against overheating
- Easy maintenance with service cover and easy detachment with smart connection socket



▶ Filters

- G class according to EN 779
- Cleanable
- Leakproof sledge design
- Easy service with side and down service covers



▶ Body of the Unit

- High Corrosion resistant sheet metal painted
- Easy maintenance with service doors
- Easy service
- Flame retardant thermal and sound isolation
- Easy mounting with hangers

Performance Datas

		CHR							
		800	1200	1500	2100	3000	4000	5000	6000
Electrical Connections		1~230 V 50 Hz							
Performance Datas									
Air Flow ⁽¹⁾	m ³ /h	850	1300	1500	2100	3100	3900	5100	6100
Sound Level ⁽²⁾	dB (A)	44	45	46	48	49	50	52	53
Electrical Requirements									
Fan/motor Power ⁽³⁾	W	240	310	420	450	750	960	1360	1840
Maximum Current	(A)	0,9	1,36	1,8	2	3,5	4,8	6	3,8

¹ Airflow data when the ESP is 0 Pa.

² Sound levels are measured at 250Hz and at 1,5m distance.

³ Power consumption

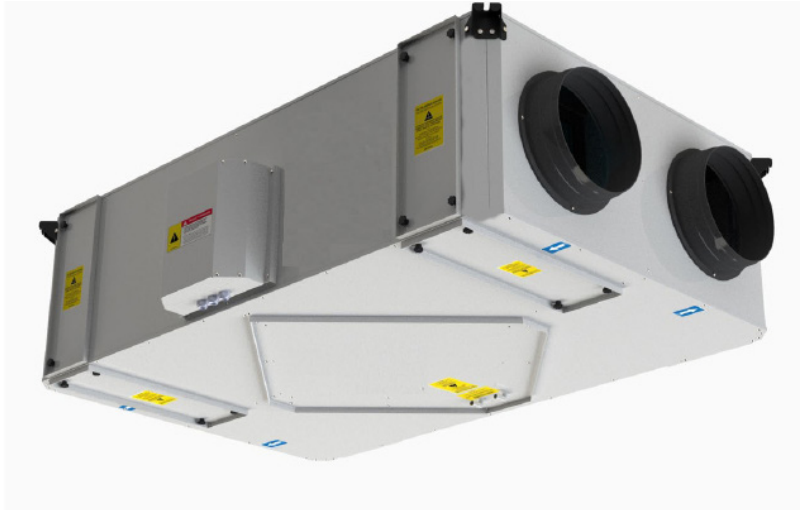

Performance Datas

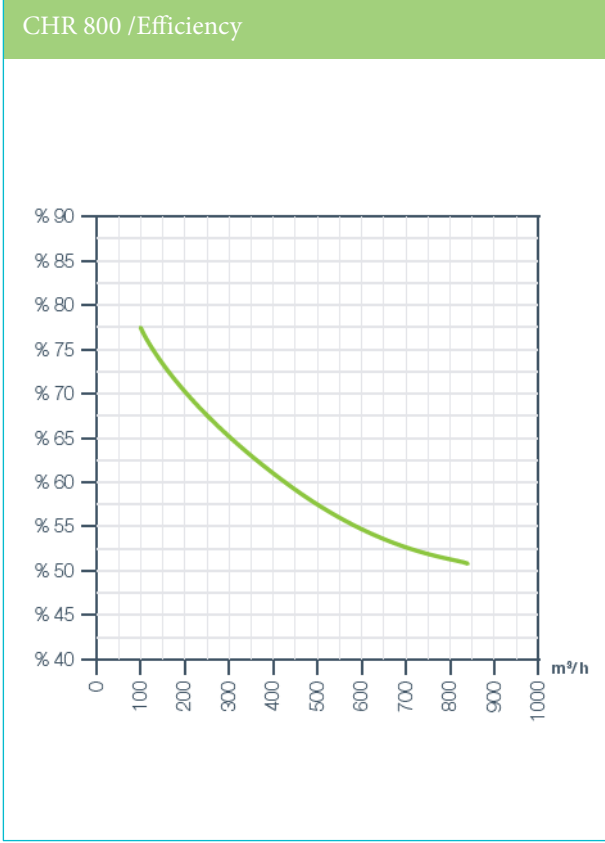
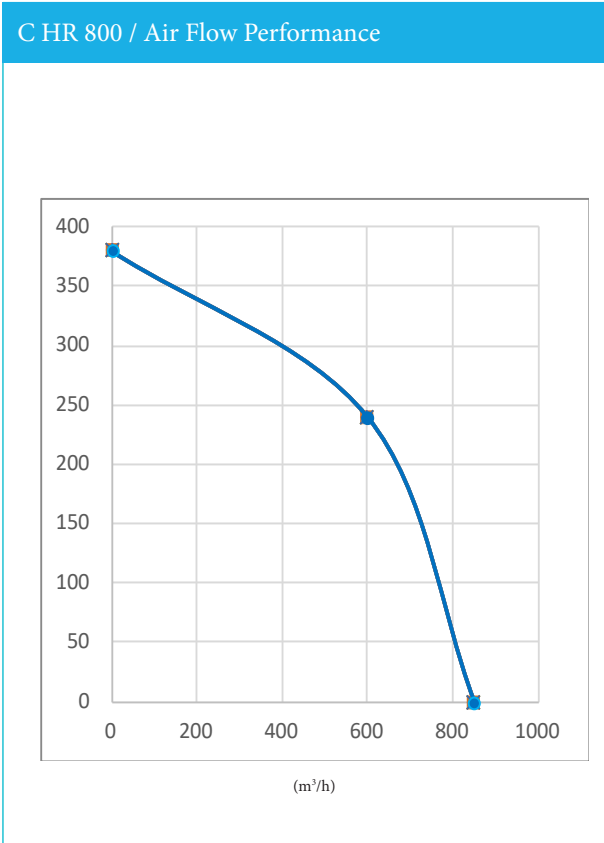

DIMENSIONS [mm]

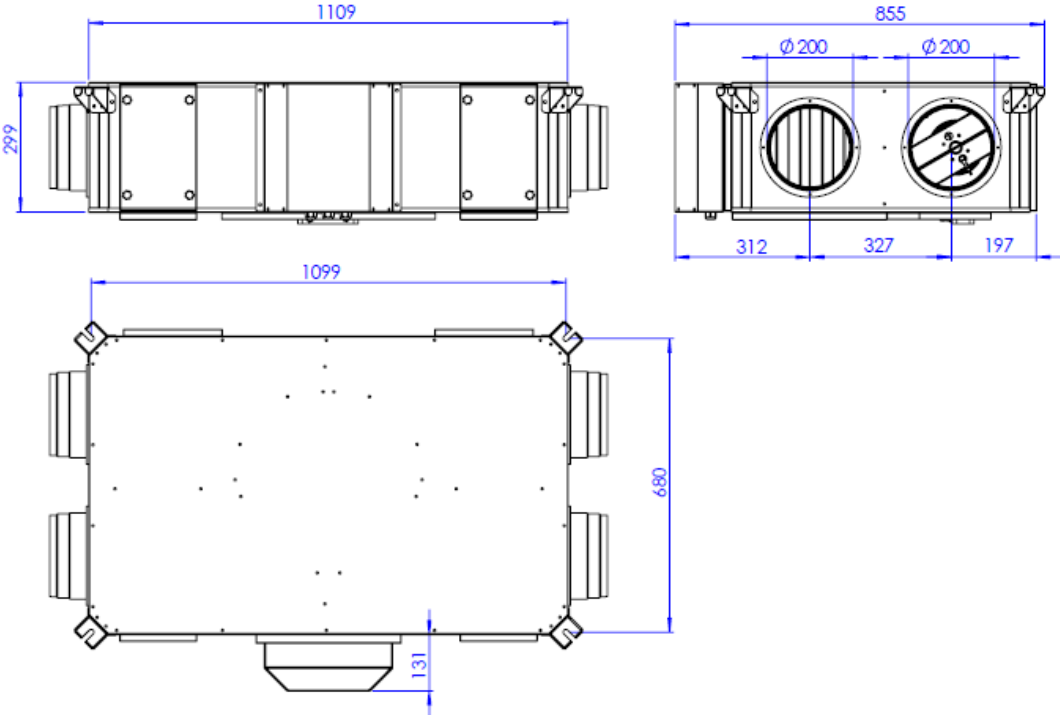

Performance Datas

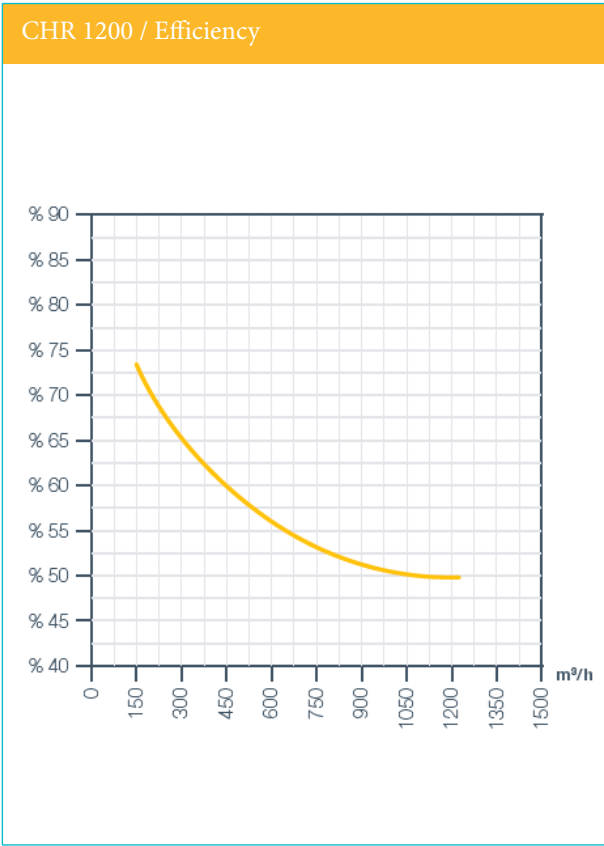
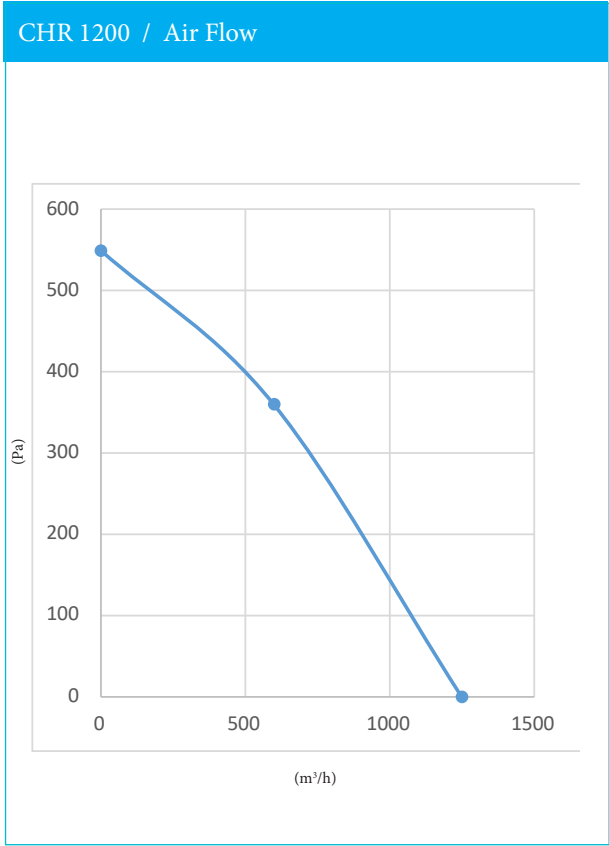

DIMENSIONS [mm]

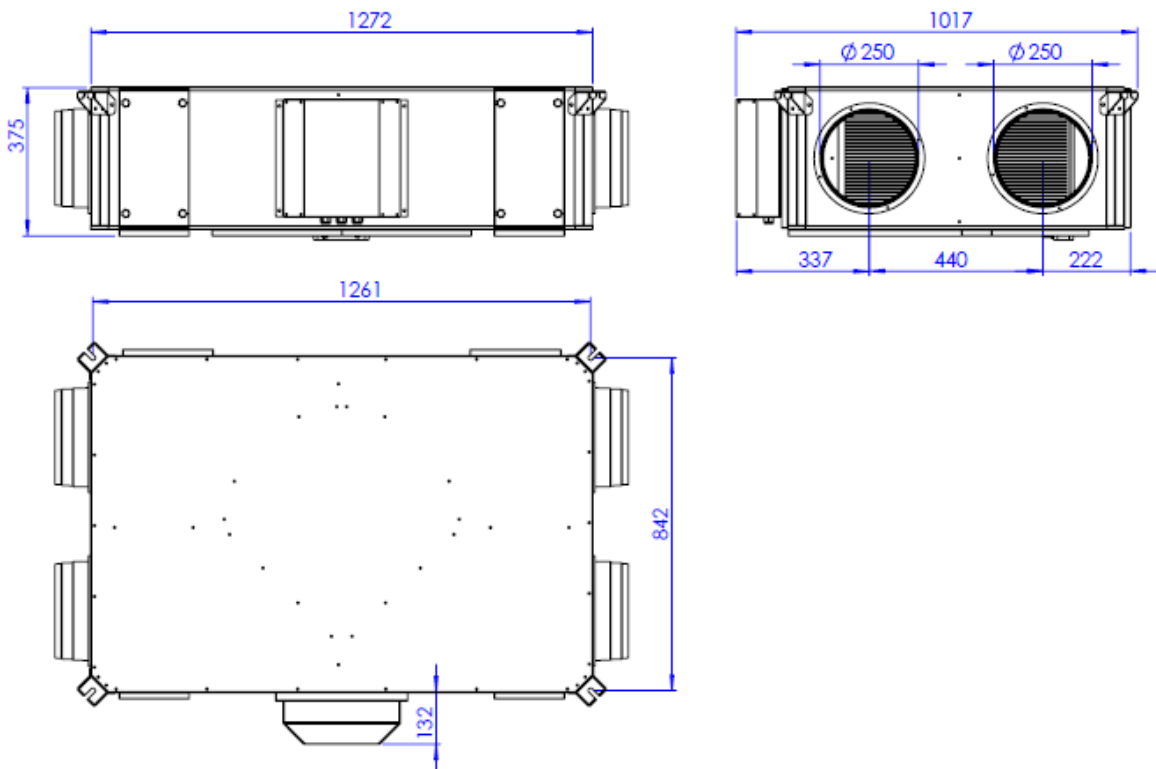

Performance Datas

►CHR 1500 / Air Flow Performance

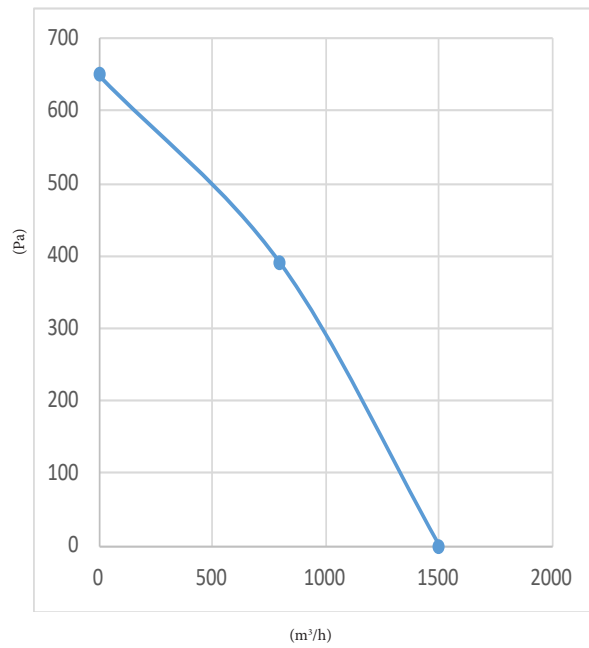

CHR 1500 / Efficiency

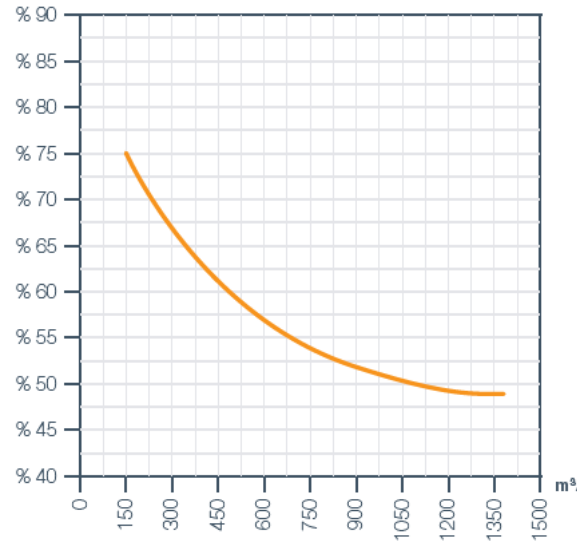

DIMENSIONS [mm]

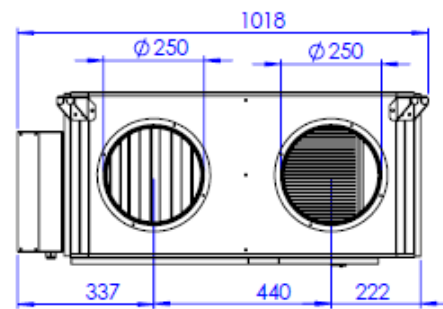
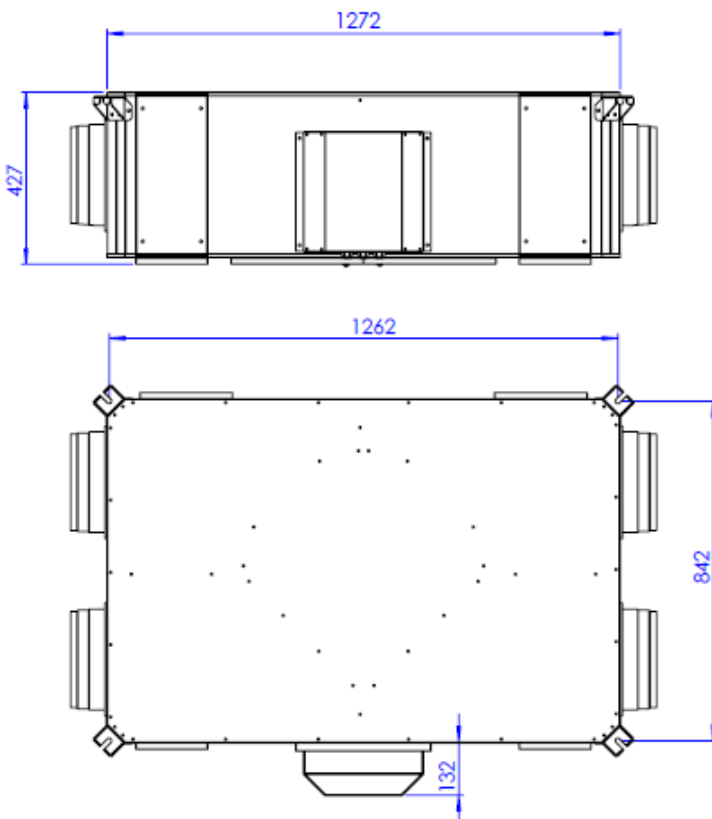

Performance Datas

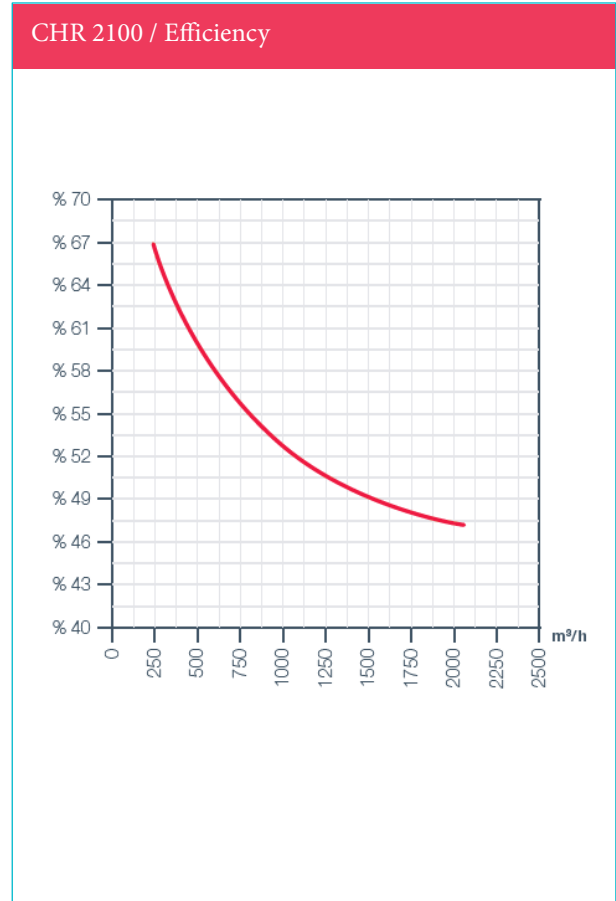
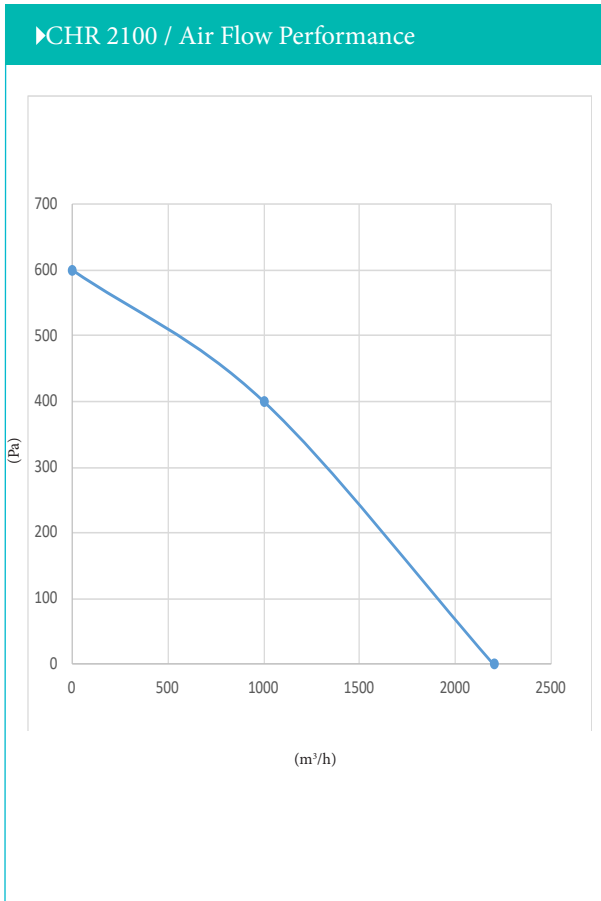

DIMENSIONS [mm]

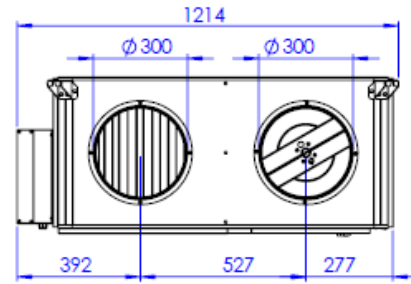
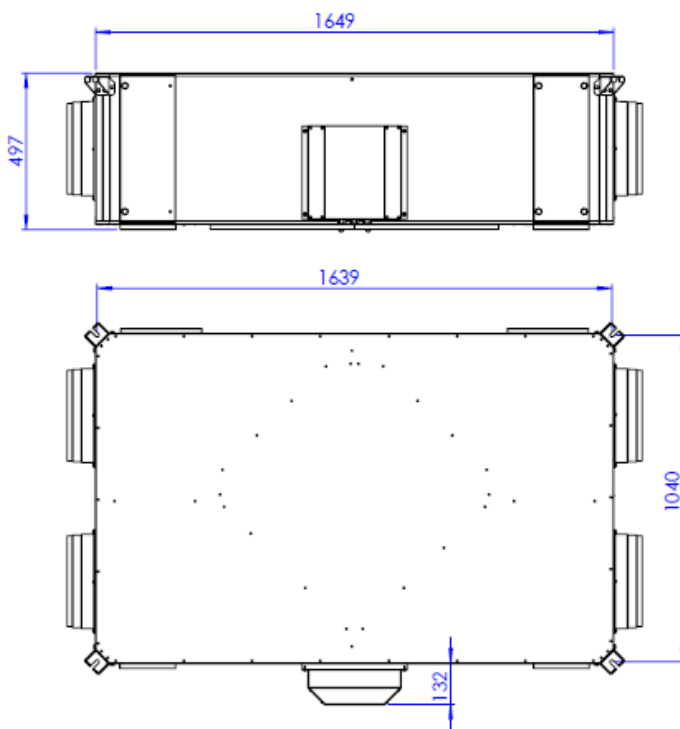

Performance Datas

► CHR 3000 / Air Flow Performance

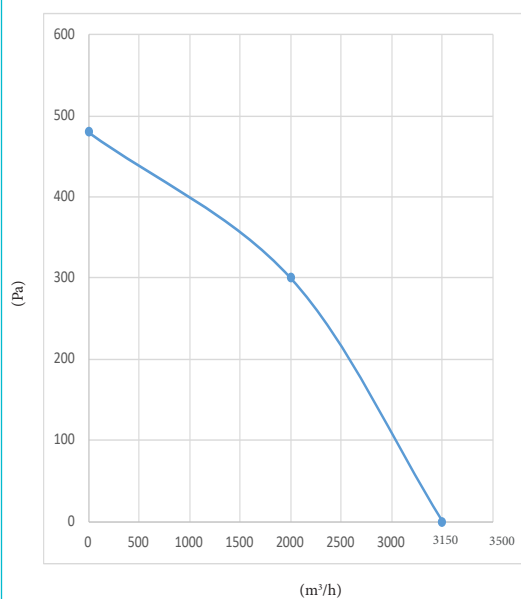

CHR 3000 / Efficiency

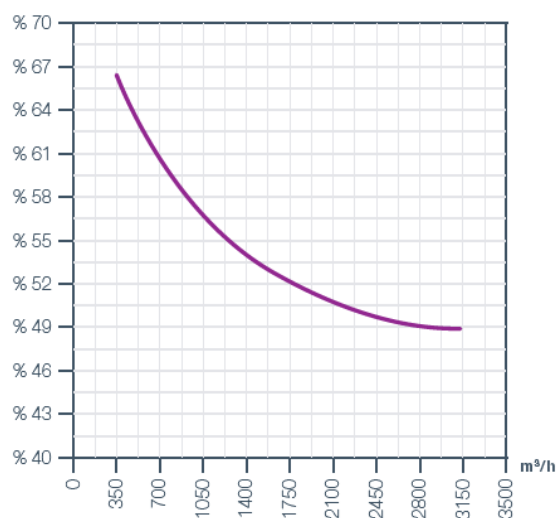

DIMENSIONS [mm]

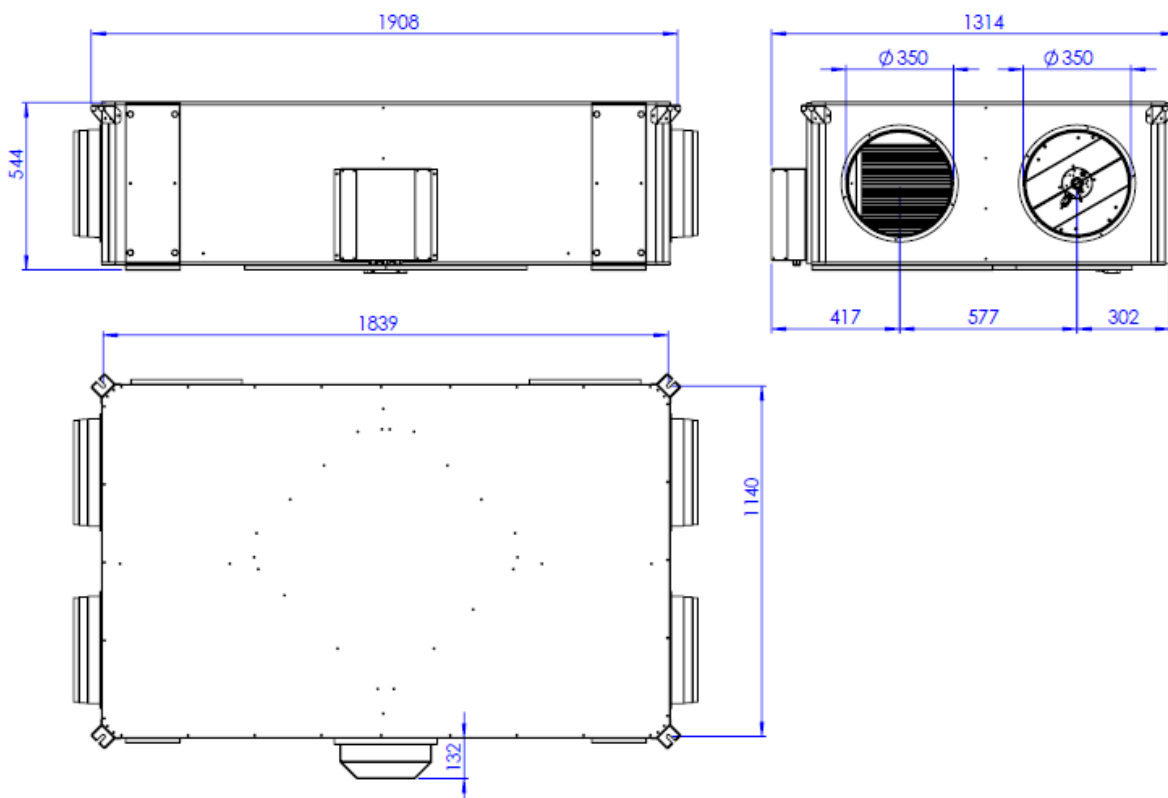

Performance Datas

► CHR 4000 / Air Flow Performance

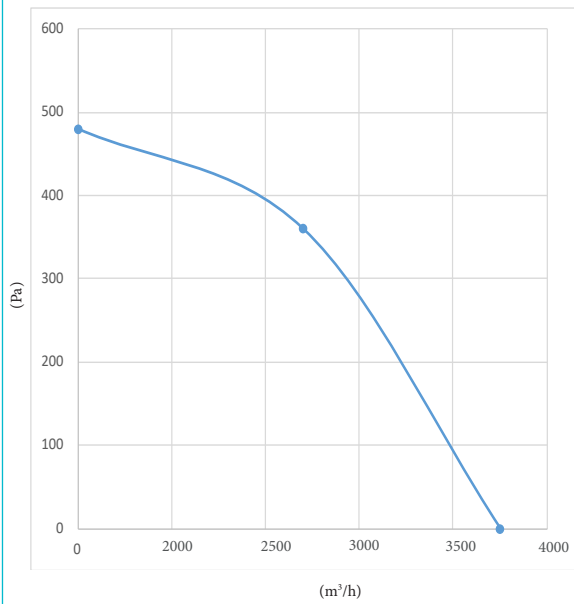

CHR 4000 / Efficiency

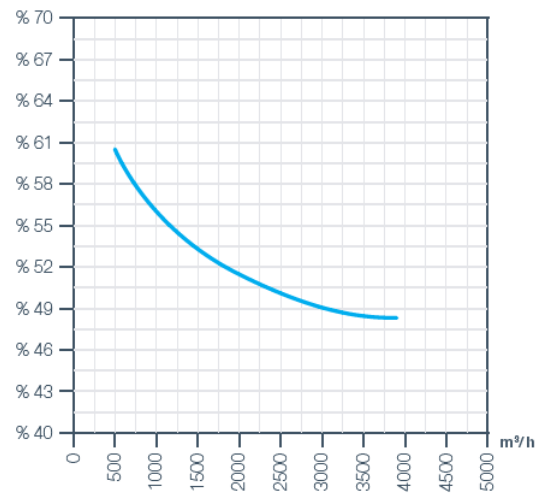

DIMENSIONS [mm]

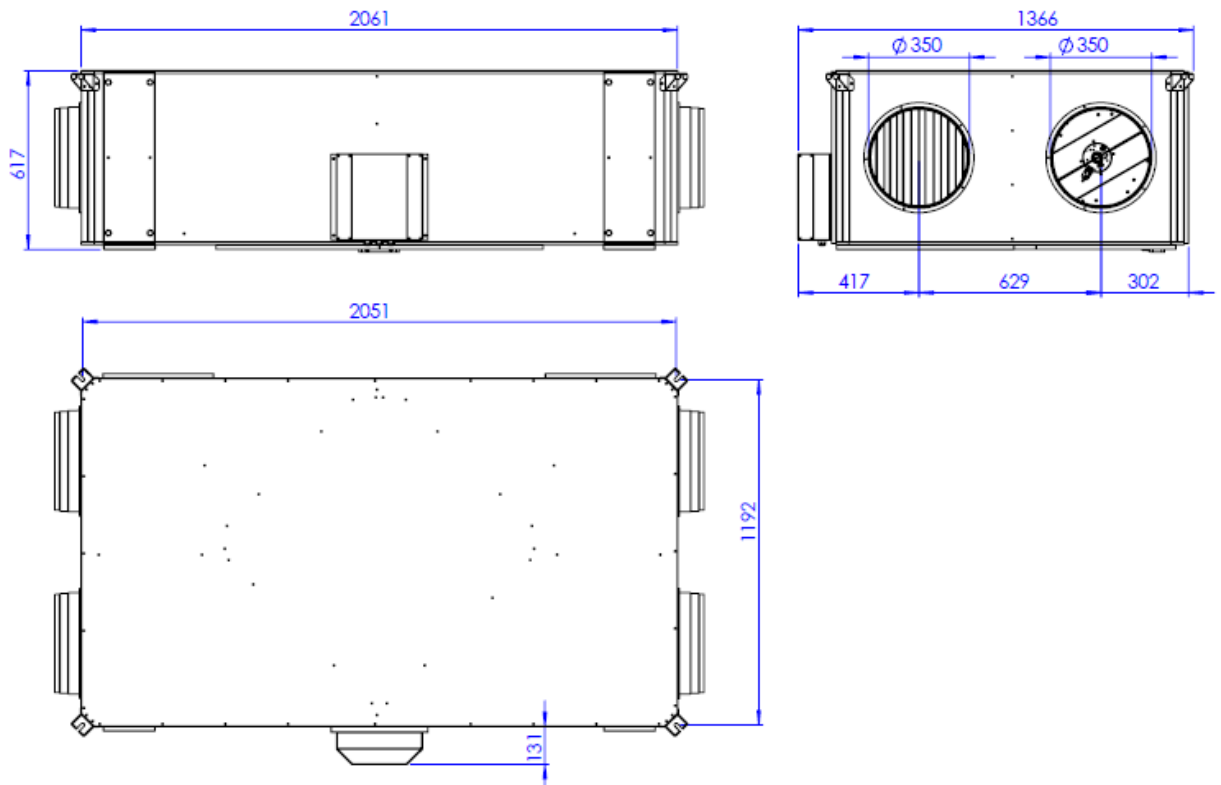

Performance Datas

►CHR 5000 / Air Flow Performance

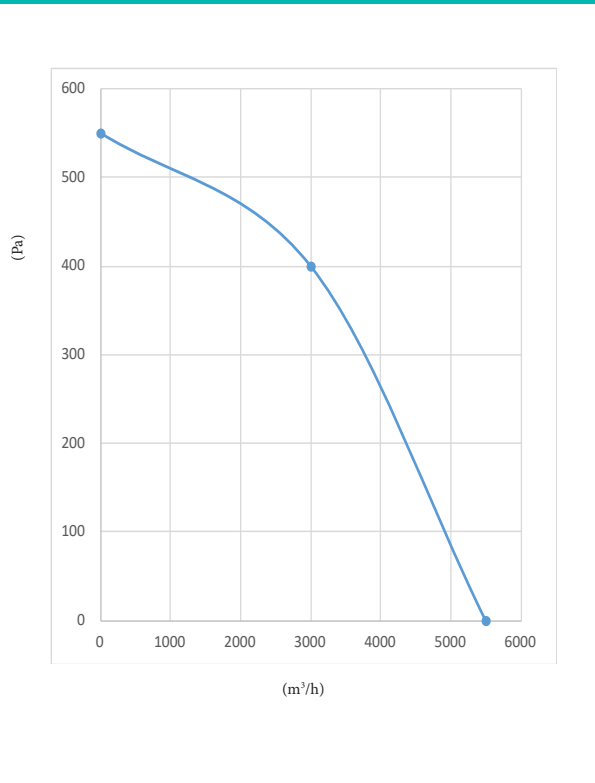

CHR 5000 / Efficiency

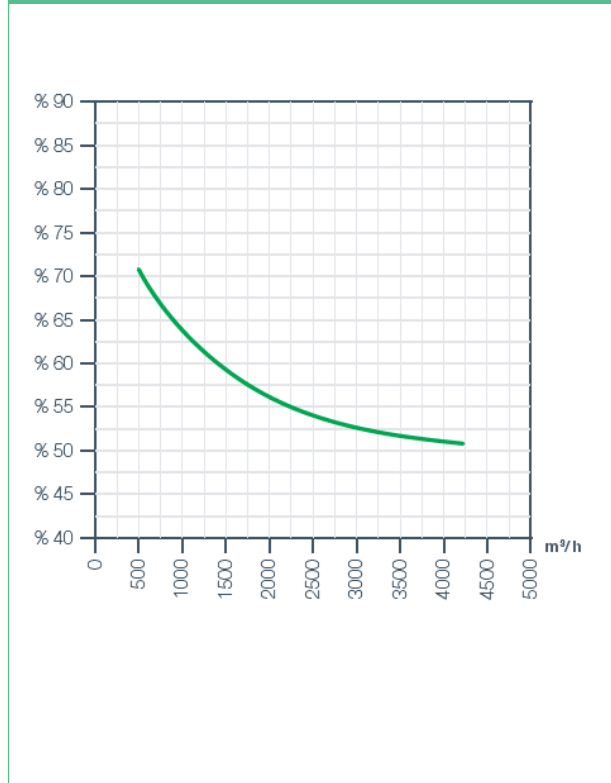

DIMENSIONS [mm]

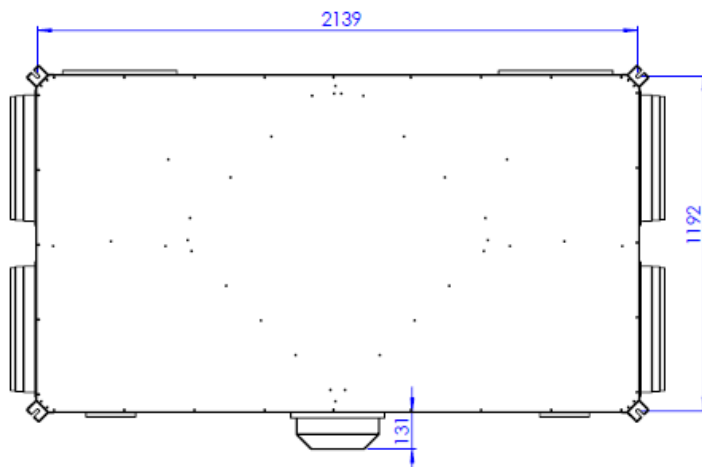
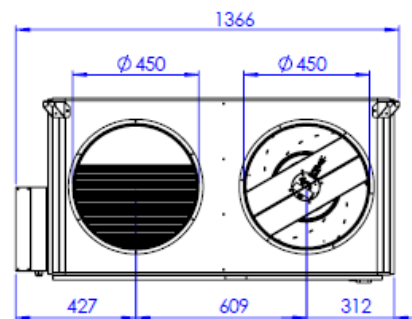
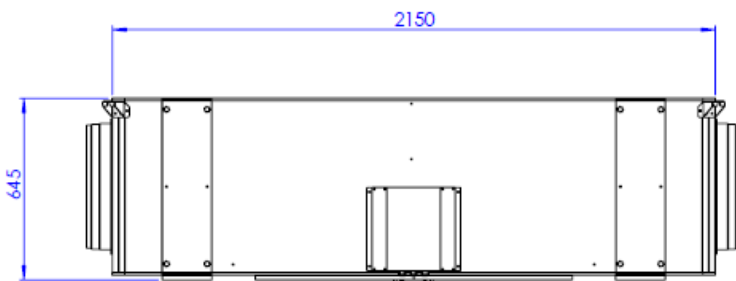

Performance Datas

CHR 6000 / Air Flow Performance

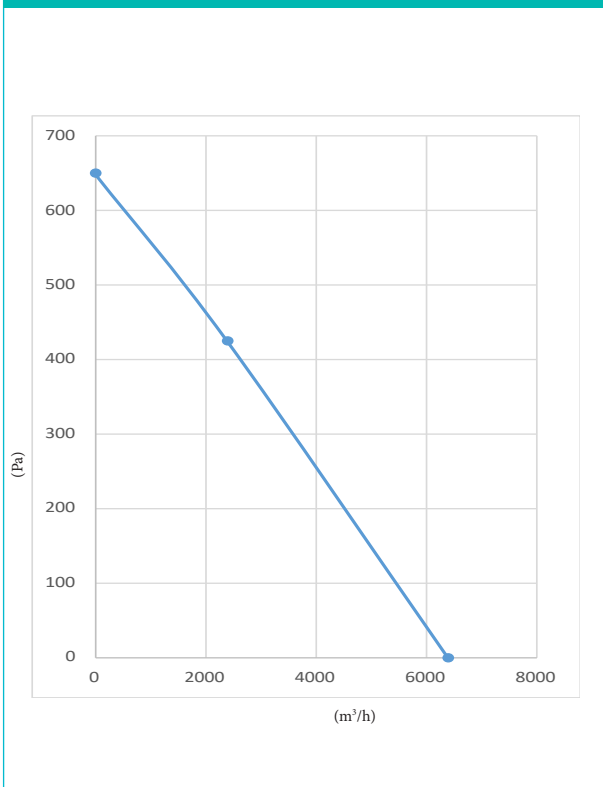

CHR 6000 / Efficiency

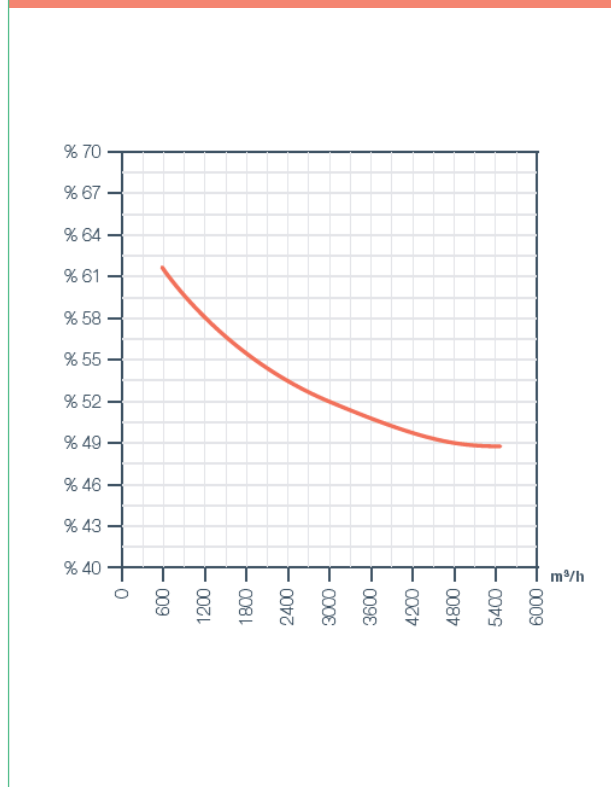

DIMENSIONS [mm]

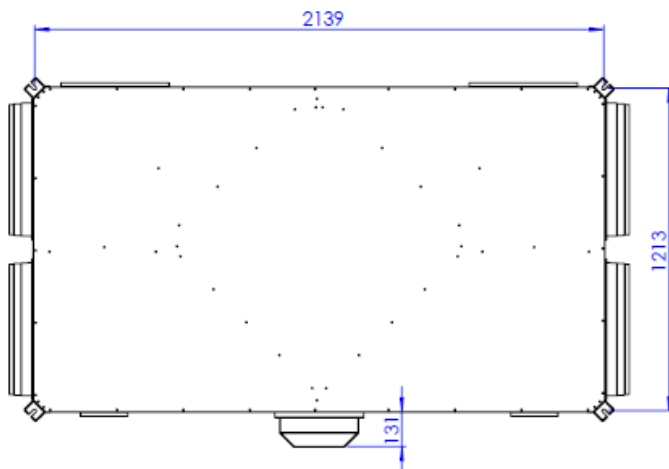
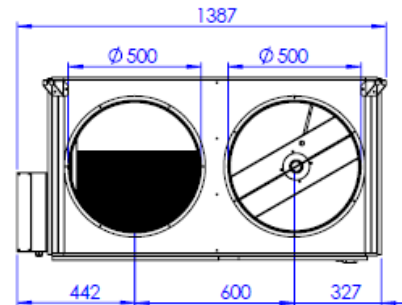
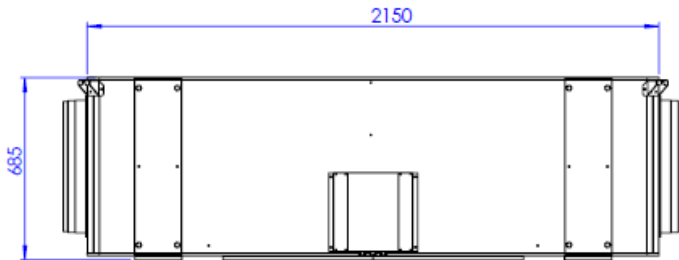

Accessories

► Digital Room Controller

CHR units are supplied with a digital room control panel. It can control air flow while changing the exhaust and fresh air flows individually (L/M/H). All the changes could be followed on LCD screen. The mode of the unit can be adjusted to winter or summer. In summer mode only the unit works. In winter mode, Unit and electrical heater works. According to the temperature adjusted on the control panel, electrical heater start up automatically. The "off" button on the control panel stops both electrical heater and unit.

Electrical board comes with the unit, it adopts unit orders coming from room controller. Components like relay, contactor, capacitor and connector are located in electrical board. Required electrical power should be supplied to heater and also to unit

CHR Units can connect to Building Automation System via contactor or MODBUS (RS485). Thereby all the features of the unit can be controlled through a centralized system.

Fresh air and return air flows can be adjusted with automation panel. Thus, negative or positive pressure could be obtained.

By using Air Quality or CO2 sensors (optional) Ventilation on demand feature could be started. To use it, either room control panel or building automation panel should be taken to VOD mode.

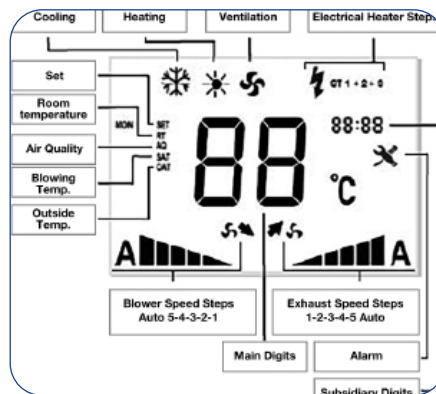
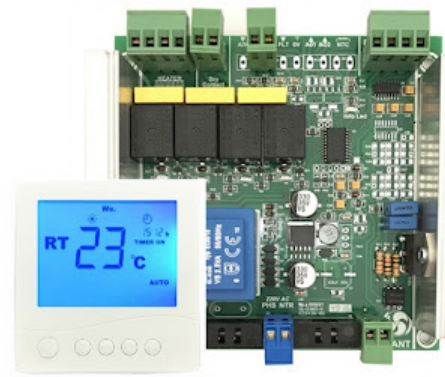

► Advanced Panel Specifications

- 1 Manages exhaust and fresh air fan volumes individually in 6 steps
- 2 Filter service alarm after 1200 hours of performance
- 3 Thermal protection for motors
- 4 Electrical heater connection
- 5 Water Coil connection
- 6 Protection of heaters for over-heating
- 7 Boost Function
- 8 Carbondioxide sensor connection
- 9 Control of damper motor
- 10 BMS control
- 11 Control of heating and cooling coil valves
- 12 Fire alarm
- 13 Weekly programming
- 14 Thermal check with a sensor located on duck

Accessories

► Electrical Heater

- Control board
- Overheat sensor, thermistor
- non-flammable macaron for electrical cables
- Low energy consumption with step control
- Rectangular shape
- Galvanised steel body

Model	Electrical Power	Step
	kW	
CHR	800	1
	1000	1
	1500	1
	2000	2
	2500	3
	3000	3
	4000	3
	5000	3
	6000	3



► Hot Water Coil

Confidenceair hot water coils are used at the exit of fresh air duct or inside the duct. They are made up of copper pipe, aluminium wings and brass collectors. The electrical board starts up the coil on/off according to set temperature with room controller. They have low pressure drops and can connect to duct system without using additional connection systems.

Air flow	Heating Performance (90/70°C)		Waterside pressure drop
	Capacity	Blowing Temperature	
m³/h	kcal/h	°C	kPa
900	4190	34	3
1060	5784	36.5	5.34
1400	9129	40.5	21.5
1600	11070	41.5	31.8
1725	12760	45.5	37
1800	17620	49.5	32.4
1900	20551	55	66.8
2450	25778	54	30.6

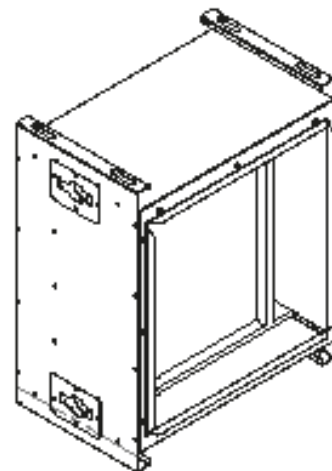



confidence
air

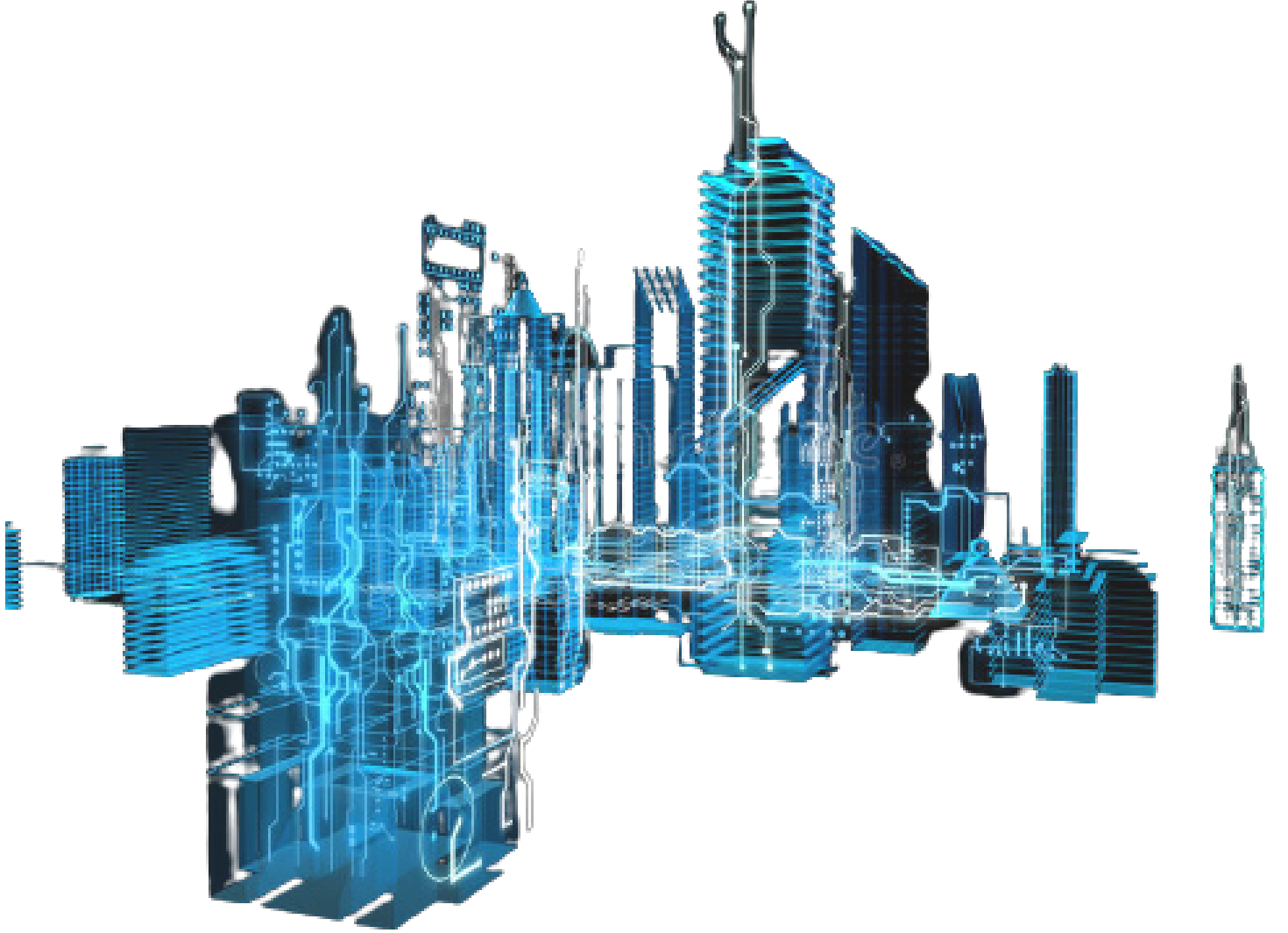

Confidenceair İklimlendirme ve Filtrasyon Sistemleri

www.confidenceair.com

info@confidenceair.com

Yunus Emre Mah. 4170 Sok. No:21-A

Karabağlar/izmir

TURKEY